

## Instruction manual

# Sensor-Line S 401

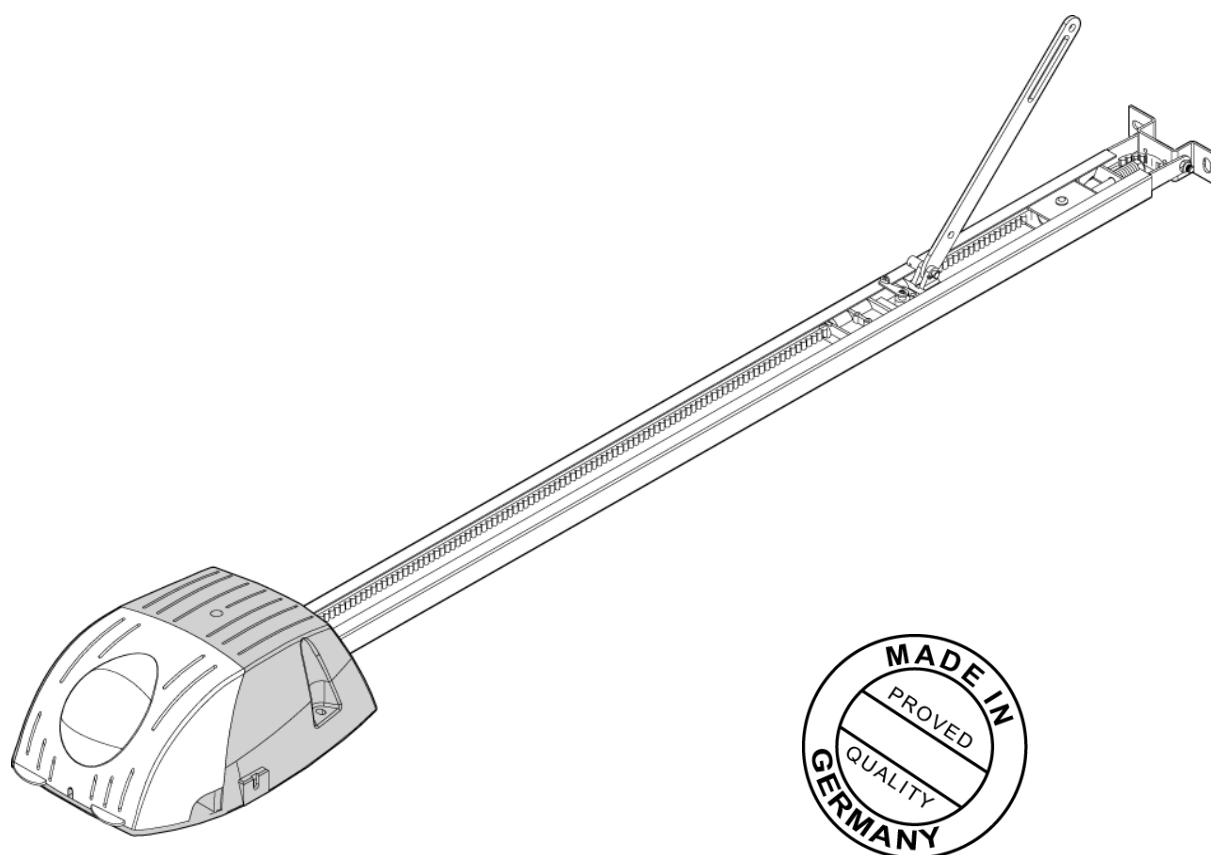

**Please keep this manual in a safe place.**





## Index

<b>1.0 Technical Data .....</b>	<b>3</b>
<b>2.0 General Instructions.....</b>	<b>4</b>
2.1 General safety instructions.....	4
2.2 Designated use .....	4
2.3 Indication for operating.....	4
<b>3.0 Drive assembly .....</b>	<b>6</b>
3.1 Scope of supply.....	6
3.2 Required tools .....	6
3.3 Installation requirements.....	6
3.4 Assembly .....	7
3.5 Installation.....	9
3.6 Initial operation.....	13
3.6.1 Insert red/green light module.....	13
3.6.2 Functions and connections.....	14
3.6.3 Set-Up .....	15
3.6.3.1 Adjustment of force and travel .....	15
3.6.3.2 Individual adjustments .....	15
3.6.4 Perform safety check.....	18
3.6.5 Warning notices.....	18
3.6.6 Radio .....	18
3.6.6.1 Installation of the radio.....	18
3.6.6.2 Set-Up of the radio.....	18
3.6.6.3 Testing the radio .....	18
<b>4.0 Maintenance.....</b>	<b>19</b>
<b>5.0 Demounting and disposal.....</b>	<b>19</b>
<b>6.0 Failure analysis.....</b>	<b>20</b>
<b>7.0 Operating Instructions radio system PICO, 868,5 MHz .....</b>	<b>21</b>
<b>8.0 TÜV-Certificate.....</b>	<b>22</b>
<b>9.0 TÜV-Doors.....</b>	<b>22</b>
<b>10.0 EC-Manufacturer's Declaration .....</b>	<b>23</b>
<b>11.0 EC- Manufacturer's Declaration according to EC Directive.....</b>	<b>24</b>
<b>12.0 Handing over .....</b>	<b>24</b>

## 1.0 Technical Data

Description		S 401-60	S 401-80	S 401-100	S 401-120
head variations	standard circuit board	B 300.01			
	optional red / green light module (red / green light red/ green, 230VAC, 50Hz, 1A)	B 300.04			
electric supply		230 V / 50 Hz			
temporary peak load		max. 600 N	max. 800 N	max. 1000 N	max. 1200 N
motor voltage		0 – 24 VDC			
circuit board voltage					
motor power		max. 110 W	max. 120 W	max. 150 W	max. 180 W
tractive- /pressure power		max. 600 N	max. 800 N	max. 1000 N	max. 1200 N
switch-on-time		30%			
speed (without load) max.		14cm/sec			
lighting		40W/230V (E14)			
duration of lighting		30-180 sec			
Radio (standard delivery)		868,5 MHz			
ambient temperature		-20°C/ +40°C			
idle running – power loss		< 1 W			
fusible cut-out		F1:3,15AT/250V F2:6,3AT/250V	F1:3,15AT/250V F2:6,3AT/250V	F1:3,15AT/250V F2:10AT/250V	F1:3,15AT/250V F2:10 AT/250V
minimum mounting height		35 mm			
overall drive length		3,31 m			
head height		145 mm			
ca. weight (with 3,00m rail)		ca. 18 kg			
travel path (with 3,00m rail)		2,40 m (with extension up to 5,4 m possible)			
max. area of door / max. weight of door (smooth running, good balanced doors)		4,5m 100kg	5,5m 140kg	6,5m 160kg	7,0m 170kg

## 2.0 General Instructions

This instruction manual is being released by BERNAL without any warranty. BERNAL reserves the right to make changes or modifications on the equipment at any time and on this manual without giving any prior notes.

### 2.1 General safety instructions

#### Important Safety Instructions:

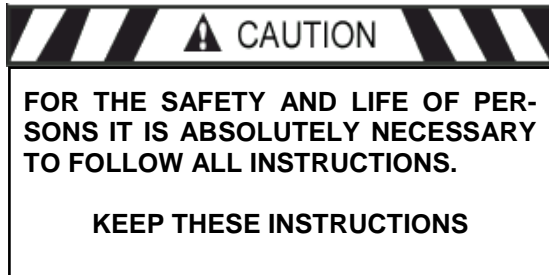

 **Qualified personnel should only perform the assembly and installation of the garage door opener. Faulty installation may lead to serious injuries! Disconnect power plug before any work on the device is done. (except on test and learning procedures) !**

 **On installation the relevant regulations for the operational safety act / employers mutual insurance association have to be followed, e.g. UVV, DIN EN 60335-1 and VBG4.**

 **The electro installation has to be performed by a qualified electrician, and has to conform to the relevant industrial safety regulations, according to DIN VDE 0100 and DIN VDE 0113. The power point must be easily accessible and at a max. distance of 50cm from the opener head.**

 **Do not operate the garage door opener at all, until it is confirmed, that the garage door is in accordance with the safety norm 98/37/EG and a valid EC-Declaration of Conformity certificate is issued.**

➤ **An improper installation or any change to the opener without the manufacturers previous approval, any warranty or product liability is null and void. The installation has to be performed in accordance with this instruction. The installation of foreign elements endangers the safe operation of the opener and is not permitted.**

➤ **You have to pay attention that the relevant national VDE-regulations for operating electrical appliances are strictly adhered to. We do not take any responsibility for the improper operating or maintenance of the door, accessories and the opener.**

### 2.2 Designated use

- **The garage door opener is designed only for the operation with well-balanced swing- and sectional doors in the non-commercial sector. The recommended max. door measurements are listed under 1. Technical Data. The door has to be in accordance with the valid specifications (e.g. DIN EN 12604 and DIN EN 12605). Before mounting the opener, check that the door can to be easily moved by hand.**
- **The opener is designed for the operation in dry rooms.**
- **The garage ceiling has to be constructed, so that a safe attachment of the opener is assured.**

### 2.3 Indication for operating

- **For garages without a second entrance, a emergency release is necessary. A function test of the emergency release has to be carried out monthly!**
- **Do not hang on the cord of the emergency release with your weight!**
- **Make sure, that the emergency release of the opener does not collide with the roof rack or any protrusions of the vehicle or the door.**
- **Instruct all persons, who are using the garage door and opener, about a safe and proper handling. Demonstrate and test the reversion (with a 50 mm high obstacle at max. 150 N) as well as the mechanical unlocking.**
- **Operate the door only, when you can see the whole door area unobstructed. Pay attention, that there are no persons or any objects in the door operating area.**
- **Wait until the door stands still. Persons or vehicles are only allowed in door operating area, when the door is completely open and at standstill.**



Do not permit children to play with the automated garage door. Transmitters are to be kept safe and away from children !

- Fixed accessories (like key switch or similar) have to be attached in sight of the door. The accessory distance to the moving parts of the door, and at a minimum mounting height of 1,80m. Accessories have to be installed beyond the reach of children! Alert stickers against pen in have to be put close to the fixed key switch.

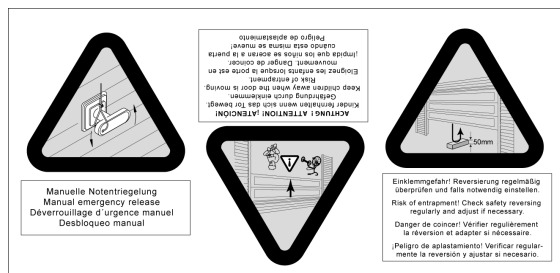

- Door, opener and extra installed safety accessories have to be checked regularly. See chapter 4 maintenance.
- Attention:  
The door can shut down faster with weak, broken or damaged springs or a defective counterweight. Under this circumstances using the emergency release may lead to uncontrolled movements of the door.
- When service- or adjustment work is urgently required, do not use the opener . A badly balanced door, or a faulty garage door drive may cause damage and injuries.

### 3.0 Drive assembly

⚠ **CAUTION** ⚠

IMPORTANT INSTRUCTIONS FOR A SAFE MOUNTING

ATTENTION – INCORRECT MOUNTING MAY LEAD TO SERIOUS INJURY – ALL MOUNTING INSTRUCTIONS HAVE TO BE FOLLOWED

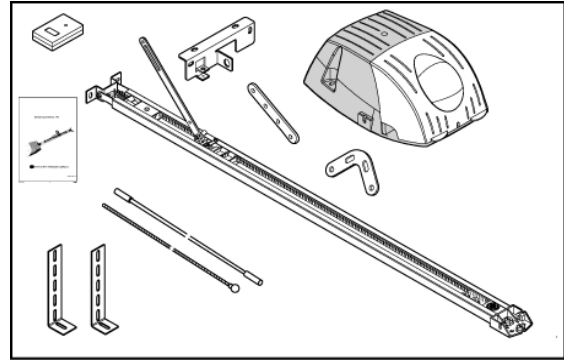

Fig.1

### 3.1 Scope of supply

The scope of supply, as shown on the Fig. 1 and 2, may vary according to the drive version.

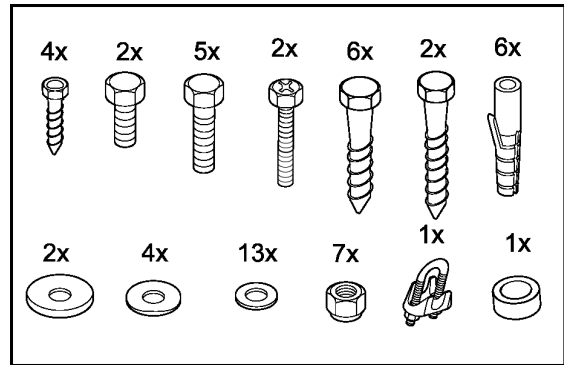

Fig. 2

### 3.2 Required tools

For the assembly and mounting of the drive the tools shown in Fig. 3 are required (not in the scope of supply).

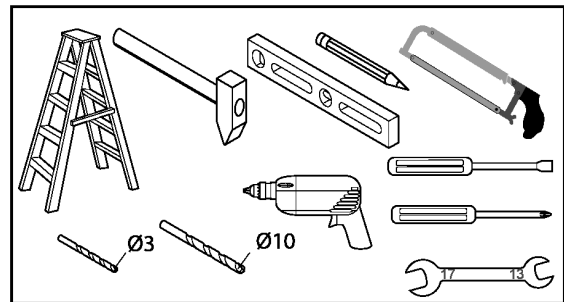

Fig. 3

### 3.3 Installation requirements

The garage door opener is suitable for the automation of spring balanced swing doors (Fig. 4a) and sectional door (Fig. 4c). (max. sizes see **1.0 technical data**).

For an optimal attachment of the push rod to the sectional door, a sectional door attachment is available as an accessory.

For doors, that are non-protruding up-and-over, a curved arm is available as accessory. (Fig. 4b)

For the mounting a minimum lintel height of 35 mm is necessary (Fig. 4).

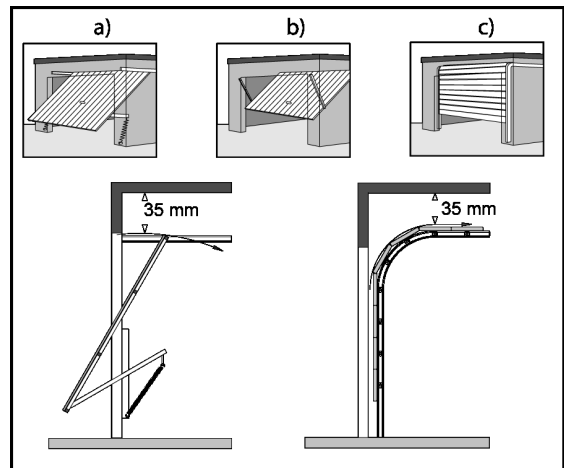

Fig. 4

### 3.4 Assembly

#### Pre-assembly of rail

According to the version, the rails have to be pre-mounted as requirements. Put the rails together via the connection rail. (Fig. 5) Slide the rails together to the stop position.

Pull the rear bracket (Fig. 6.1) together with the belt (Fig. 6.2) out of the rail. Remove the transportation covering (Fig. 6.3) and press the pinion (Fig. 6.4) into the bearing. Take care of the belt not being squeezed. Then attach the transportation covering again and push the complete rear bracket back into the rail.

Adjust the tension of the chain or belt by pulling the idler wheel towards the chain end. Make sure, that the chain lock (Fig. 7a) is on the left side of the rail. (Fig. 7)

Then push the tensioning bracket towards the end of the chain and guide the coach bolt through the hole of the tensioning bracket. Pay attention that the coach bolt fits into the tensioning bracket.

Push the provided spring and washer on the end of the coach bolt and screw the nut on the coach bolt. (Fig. 8)

#### Paste rubber buffers

If you have a chain drive, we recommend sticking the provided rubber buffers to the inside of the rail (Fig. 9c). Those serve to minimize the noise caused, when the chain touches the rail. Assure, that the rubber buffers are not in the travel path of the trolley. The buffers have to be put close to the end of the chain, so that the trolley doesn't touch them in door-closed- (Fig. 9a) or in door-open-position (Fig. 9b).

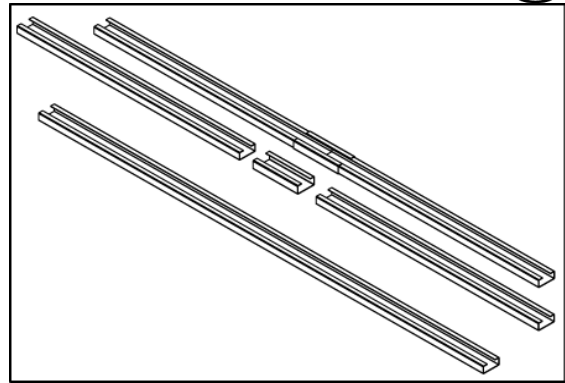

Fig. 5

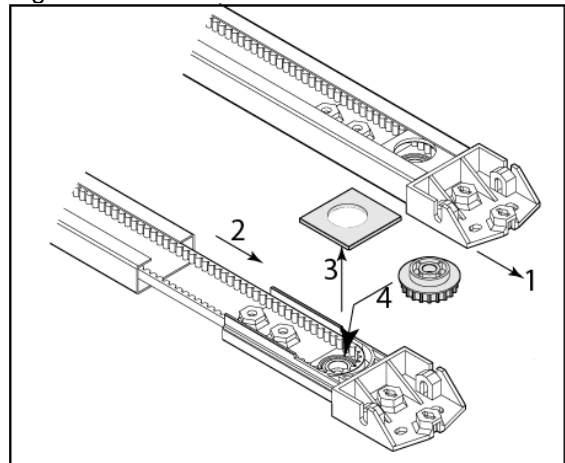

Fig. 6

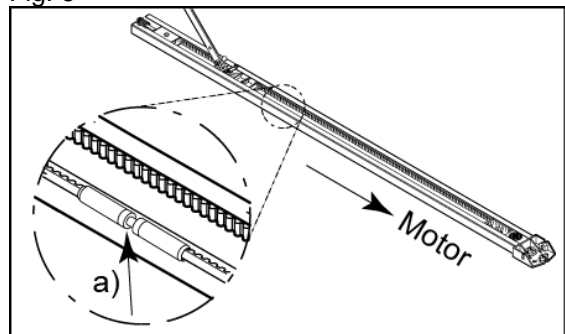

Fig. 7

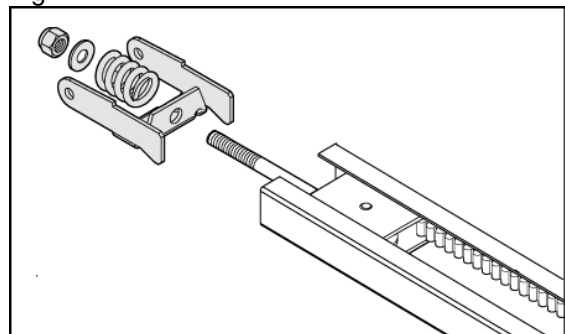

Fig. 8

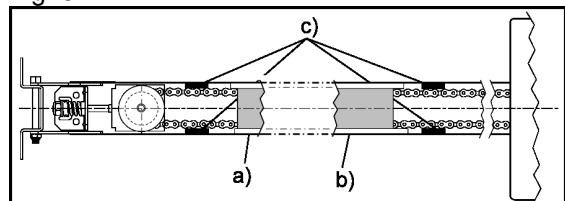

Fig. 9



### Pre-tension chain / belt

Turn the nut to tension the chain or belt slightly. Fig. 10).

### Trolley test

Check afterwards, that the trolley can easily be moved by hand. To release the trolley, from the chain lock, pushes the lever on the trolley and at the same time move the trolley in the rail (Fig. 11).

Make absolutely sure, that after this test the trolley engages on the chain lock. To perform this, move the trolley without holding the lever over the chain/belt lock and the trolley engages automatically.

### Assembly of door bracket

According to the installation situation the provided push rod components can be combined as needed (Fig. 12).

If the length of the push rod is not sufficient, it can be adjusted via the extension rod (Fig. 12a). In adoption with sectional doors, we recommend the use of a sectional door angle (Fig. 12c). Then the provided door bracket (Fig. 12b) has to be attached to the push rod. For the assembly use the provided screws, washers and nuts, and tighten them firmly.

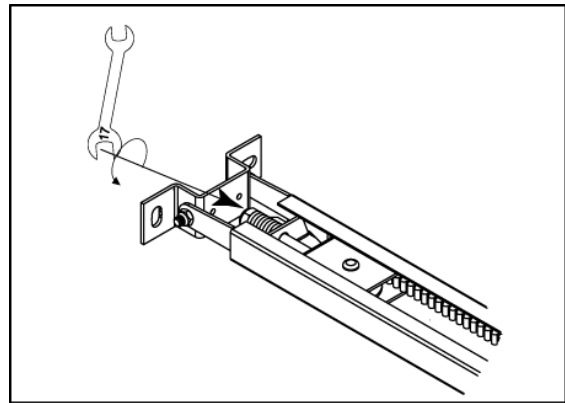

Fig. 10

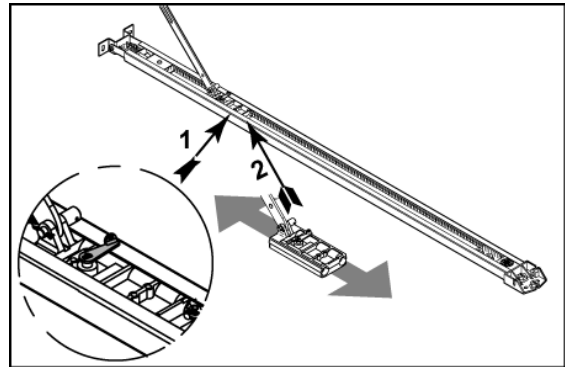

Fig. 11

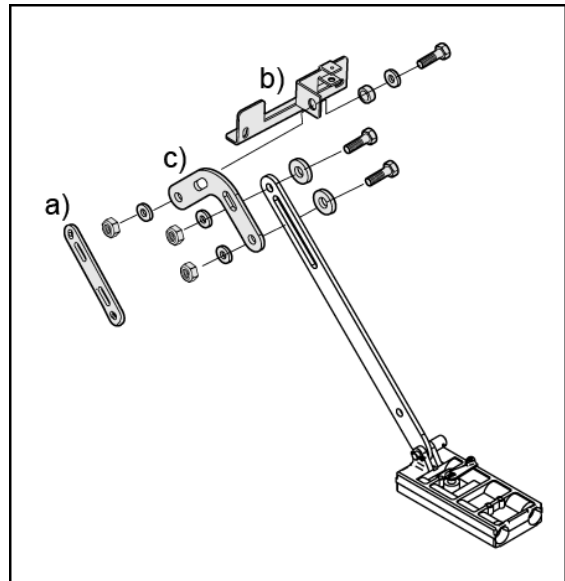

Fig. 12

### 3.5 Installation

⚠ CAUTION ⚠

Before installing the drive all mechanical locks of the door have to be put out of order!

#### Mark the middle of the door

Measure the width of the door and mark the middle of the door at the lintel. (Fig. 13)

#### Calculation of the necessary height

The rail has to be mounted on such a height, that between the highest door point (Fig. 14.1) (the highest point that the door can reach during the movement) and the lower edge of the rail, a clearance of at least 10-20 mm is available (Fig. 14.2).

Pay attention, that the rail is always mounted at a level position.

The angle  $a$  (Fig. 15) may not exceed  $30^\circ$ , otherwise a correct transmission of the power is not guaranteed.

The distance between the lower edge of the rail and the upper edge of the garage door should be between 5 and 7 cm in closed condition.

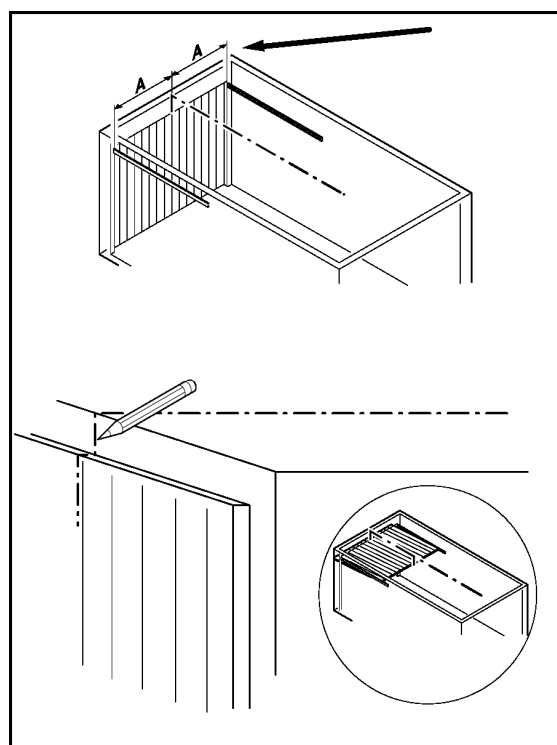

Fig. 13

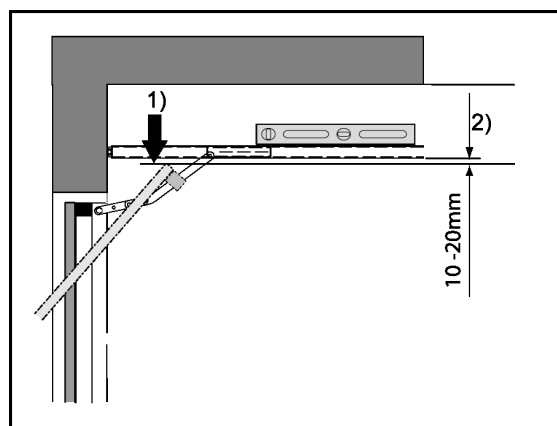

Fig. 14

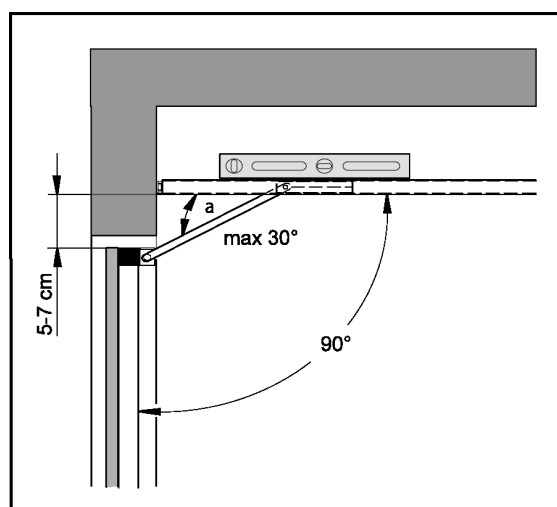

Fig. 15



## Mounting the lintel bracket

Extend the door measurements on the lintel, so that the provided head bracket (Fig. 16) is exactly in the middle of the door and above the required highest door position.

Use a pen and mark the bracket holes on the lintel and drill the required holes (Fig. 16).

**Attention: When drilling, cover the drive!**

Then attach the lintel bracket (Fig. 17) to the lintel. (depending on the installation situation the provided fastening screws have to be replaced by others).

## Attaching the rail to the head bracket

Then fasten the rail to the head bracket with a coach bolt and a lock nut (Fig. 18).

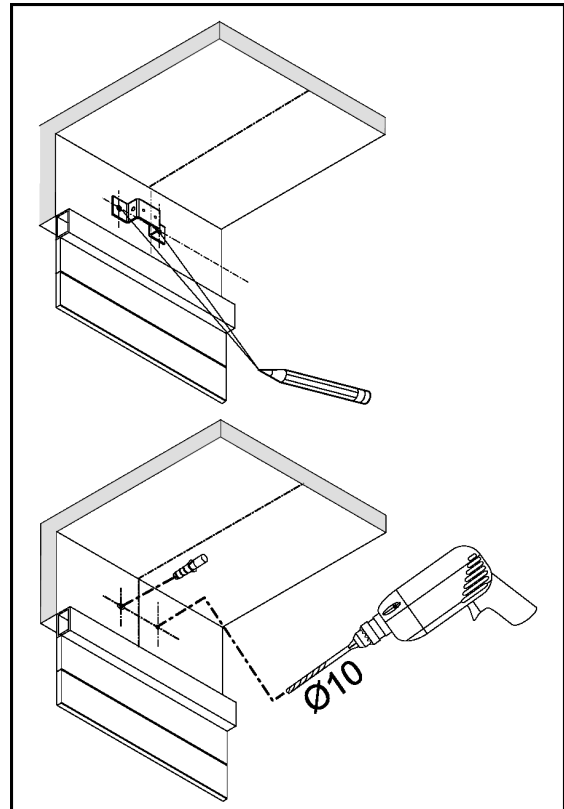

Fig. 16

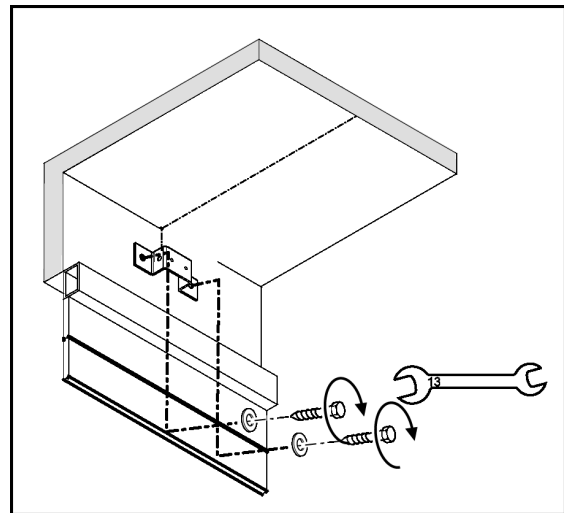

Fig. 17

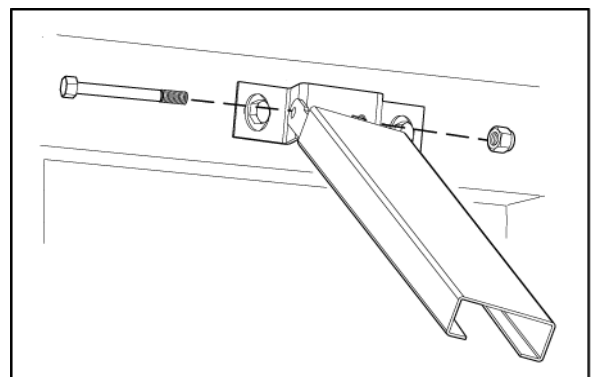

Fig. 18

**Fixing of the retaining angle**

Bring the rail in a level position, fit the retaining angles to the return head. Make sure, that the rail is in a level position. The excess lengths of the angles have to be sawed off (Fig. 19).

**Attachment of the rail**

Afterwards mark the points where the retaining angles shall be attached to the ceiling. Make sure, that the rail is aligned with the earlier marked middle of the door.

Drill the required holes and affix the retaining angles to the ceiling (Fig. 20.1).

**Attention: When drilling, cover the drive!**

**Attachment of the drive head**

The next step is to insert the drive head shaft on the collet of the return head (Fig. 20.2).

As shown in Fig. 20.3 the drive head has to be attached with the 2 Phillips-screws and spring washers to the return head.

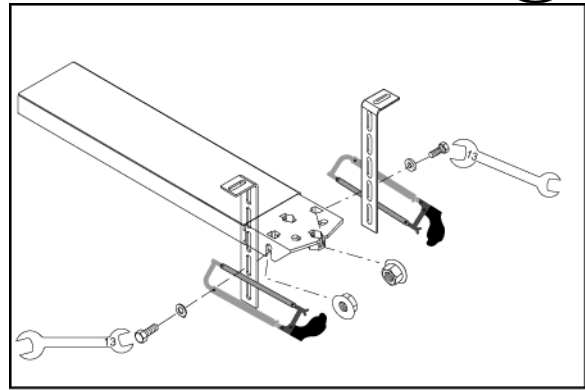

Fig. 19



Abb. 20.1-20.3



### Adjust the tension of chain or belt

Turn the nut of the tension unit (Fig. 21), so that the spring is completely compressed. Then release the tension of the spring by turning the nut back about 1 to 2 turns, until the chain or belt can be pushed together to approx. 0,5 cm distance in the middle of the rail.

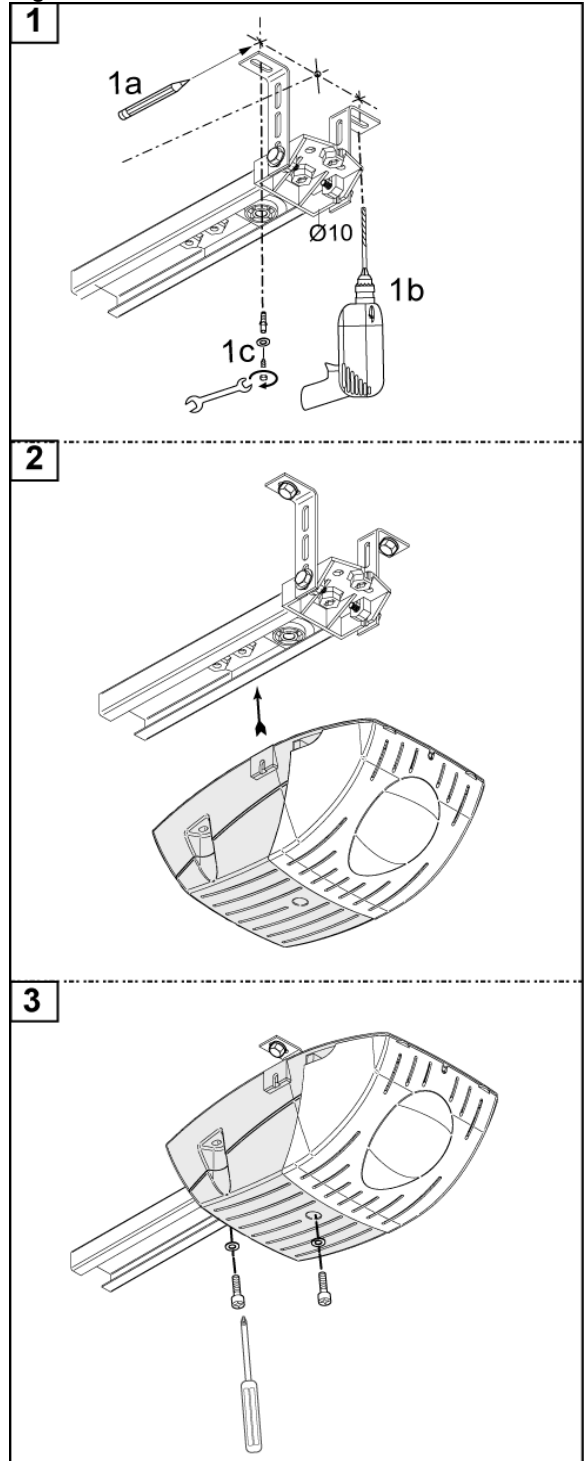
### Attachment of the door bracket assembly

First press the lever on the trolley, (Fig. 22.1) and move the trolley towards the lintel. Then mark the points of the door, where the door bracket shall be attached (Fig. 22.2). Drill the required holes at the door and attach the door bracket, with 2 screws, firmly to the door (Fig. 22.3 + 22.4).

### Installing the emergency release

If the garage is without a second entrance, the installation of a emergency release set is absolutely necessary, so that in case of an emergency the door can be opened from outside. The Bowden cable has to be moved through the eye of the „key shaft“ and the mantle. (Fig. 23.1 + 23.2) Afterwards the linkage has to be moved through the door bracket (Fig. 23.2). At the end of the installation of the Bowden cable has to be attached at the door handle (Fig. 23.3).

It is absolutely necessary, to check the correct function of the emergency release, before using the garage door opener.



**Before operating the garage door opener: unlock the trolley and open and close the door to the full stop by hand.**

**The trolley has to come to a full stop, before bumping the drive head or the return guide assembly, with the door in open / closed position.**

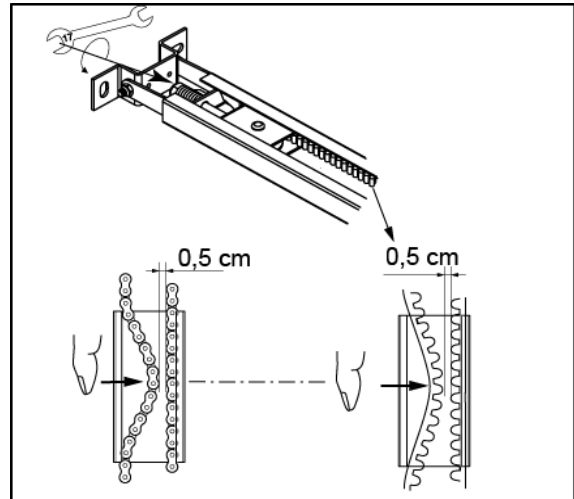

Fig. 21

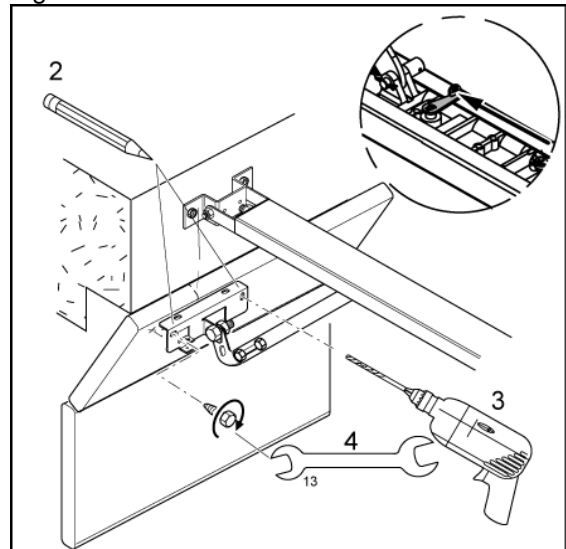

Fig. 22

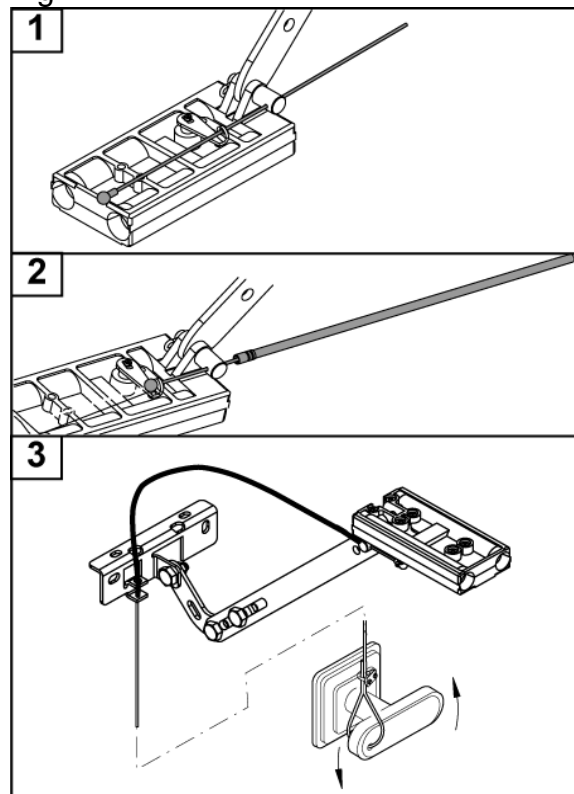
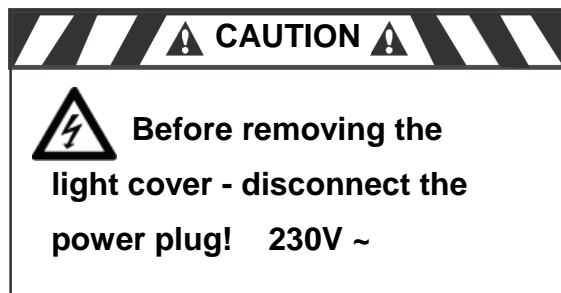

Fig. 23

## 3.6 Initial operation

### 3.6.1 Insert red/green light module

If you want to insert the red/green light module, you have to do the following steps:



At first, the 2 safety screws have to be removed as shown in Fig. 24.1 and the light cover has to be taken off. Then turn out the light bulb and the 4 screws of the cover (Fig. 24.2). Now the cover can be taken off (Fig. 24.3) and the red/green light module can be inserted (correct position see Fig. 25 circuit board layout). The red/green light module has to be attached with the provided screws on the circuit board, and the heads of the screws have to be isolated with the provided plastic covers (Fig. 24.4).

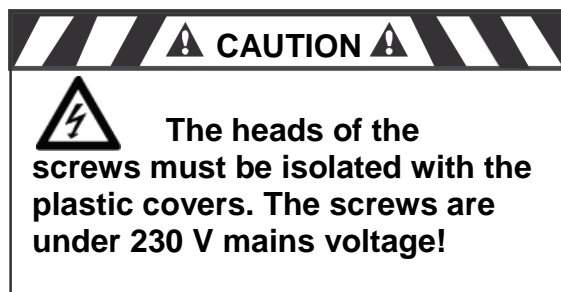

Then break out the pre-punched notch for the red/green light module in the cover and reassemble the cover – screws – light bulb and light cover. Now plug the opener to the mains.



Abb. 24.1-24.4

### 3.6.2 Functions and connections

The assembly as well as the connection- and adjustment possibilities of the circuit board are shown in Fig. 25. For the activation and set-up of some connections (for example, light barrier, safety edge, etc.) some individual adjustments as described in paragraph 3.6.3 have to be implemented.

**The standard circuit board B 300.01 has the following connection possibilities and functions:**

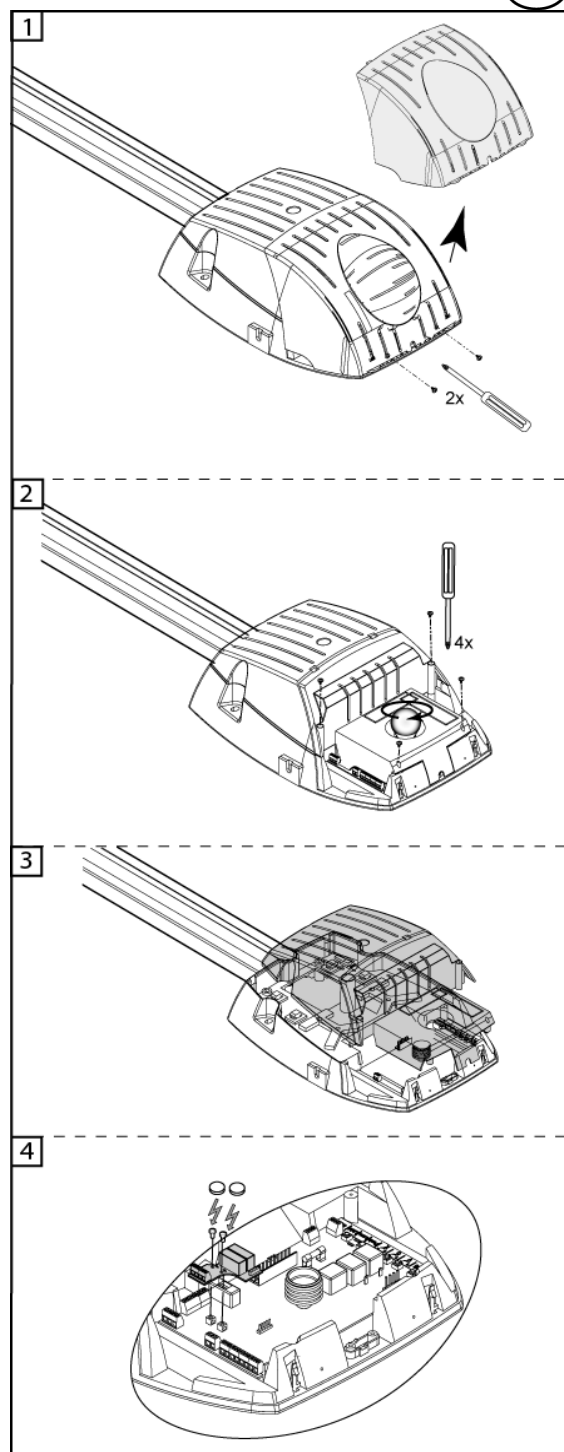
#### Start button external terminal 1 (earth) and terminal 2 (signal)

The start button on the circuit board, the start button external and the radio receiver have the same function during operation (exception: learn function). With the start button the drive can be started and stopped. During door movement, pressing the start button activates the soft-stop.

#### Emergency stop terminal 3 and terminal 4

Wire jumper bridges terminal 3 and 4, if the emergency stop is not connected. Activating the emergency stop during door open movement, the drive is immediately stopped; when activating while the door closes, the door stops immediately with reversion.

If you are using a slip door, a fail safe slip door contact has to be applied. The connection cable has to be laid fail safe. (e.g. with cable type: ÖLFLEX-CLASSIC-100 2x,5mm<sup>2</sup>).

#### Light barrier with integrated check according to safety category 2 EN 954

transmitter:

terminal 5 (+): 80 mA / 24 V

terminal 6 (-): switched earth

receiver:

terminal 5 (+): 80 mA / 24 V

terminal 7 (S): signal

terminal 8 (-): earth

*Light barrier is not connected:* terminal 7 and 8 are open, Menu b sub point 4 has to be set on 0 (=inactive). *When using a light barrier:* menu b sub point 4 has to be set on 1 (= active).

The receiver is always connected to the mains voltage.

The transmitter is only active when the drive is working. When the drive is activated, the transmitter of the light barrier receives his voltage.

The receiver is being activated via the transmitter diode and the signal of the light barrier is switched on.

Before every start the function of the light barrier is being controlled.

If there occurs an error on the light barrier, there is no start possible!

If the light barrier is activated during door closing, the drive stops and reverses (completely

or partially, according to the setting on the circuit board, menu point b1).

If there is an activation while the door opens, there is no reaction.

**CAUTION:** During the learn function, the light barrier is not activated.

#### Connection safety edge 8,2 or 22 kOhm

When using a safety edge, the menu point b sub point 5 has to be set on 1 (=active).

If there is no light barrier connected simultaneously (menu b sub point 4 =inactive) the safety edge has to be just connected on terminal 7 and 8.

With an additional connected light barrier, the safety edge has to be connected in-line with the receiver signal of the light barrier (terminal 7) (in menu b the light barrier and the safety edge have to be activated).

#### Isolated normally open output for door-closed contact or connection warning lamp on automatic closing terminal 9 and 10

230VAC / max 1A cos Phi = 1

30VDC/ max.1A

The external wires have to be protected with max. 1A delay fuses.

a) Red / green light module is not installed:

When setting menu point b3 (automatic closing) on 0 (=inactive) the clamps 9 and 10 are the door-closed contact.

When setting b3 on 1 (=active) the terminals 9 and 10 are a isolated normally open output for a warning lamp for automatic closing.

b) Red / green light module installed (optional)

The clamps 9 and 10 are generally door-closed contact.

The setting of the pre-warning period automatic closing is possible on menu point U or H (when red / green light module is plugged).

The automatic closing period (opening period) can be set on menu point A.

#### External lighting terminal 15 and terminal 16, 230 VAC/60W (max.)

After every start, according to the set adjustment time at menu L, the internal and external light is on.

#### Connection earth terminal 17

Earth e.g. for external lighting

#### Connection antenna to terminal 25 and 26

To avoid interferences with the circuit board we recommend generally: when using a pluggable receiver (MOLEX 10-pol), connect the antenna directly to the receiver. If this is not possible, a rod antenna can be connected to clamps 25 and 26.

**Attention:** Operates only in connection with a receiver plugged in the MOLEX-socket.

#### Start (button on the circuit board)

1. Starting and stopping of the drive



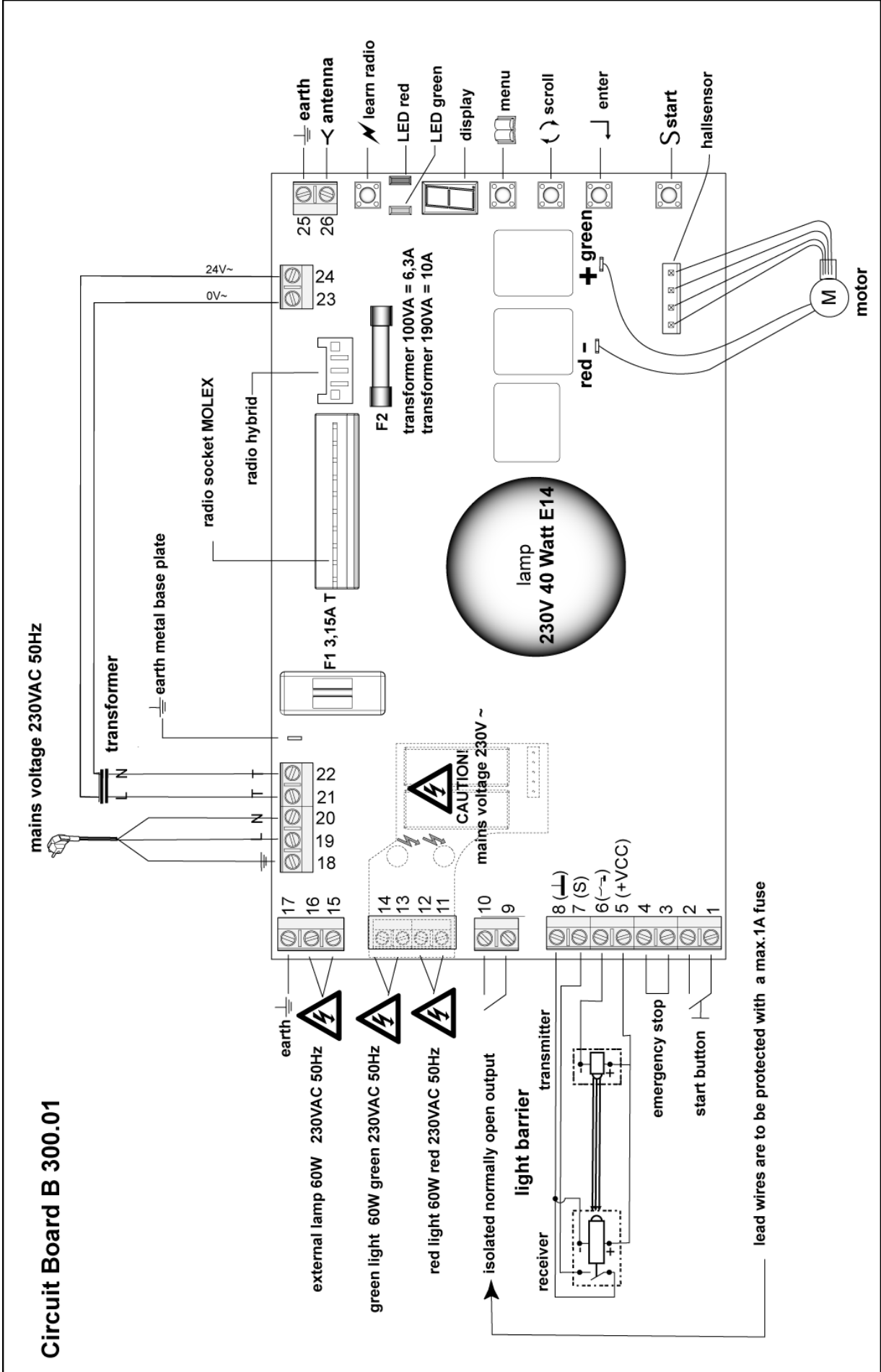

Fig. 25

### Legend

- Door movement: Up/Down arrow
- Button Impulse: Square with diagonal line
- Hold Button down: Square with circle and diagonal line
- Menu = select options: Square with circle
- Scroll = page up or down: Square with left/right arrow
- Enter: Square with left arrow
- Start: Square with 'S'
- LED permanent on: Solid square
- LED off: Empty square
- LED flashing: Square with vertical lines
- Preset values (see table): Shaded square

### Circuit Board B 300.01

### Power- and Door Travel Set-Up

During learning time, the Power setting has to be on Stage 5 (Factory Set-Up). Individual Program changes can be made later.

**Standardmode**

5 sec

**\* Holdbutton down, until ca 10-20cm before endposition has been reached. Door-Open or Door-Closed position is achieved by Short-Impulse pressing of the button.**

### Malfunction- and Statusdisplay

Malfunction

Display	Description of Malfunction	Action
0	Excess voltage on mains	auto Reset **
1	Safety edge or safety barrier active	auto Reset **
2	Access door open	auto Reset **
3	Light barrier defect or short-circuit on Cable	auto Reset **
4	Door travel is not set or setting lost	Reset through Enter new Set-up required
5	Motor-malfunction	Reset through Enter
6	Sensor-defect	Reset through Enter
7	processor-failure	Mains reset
8	ROM-failure	Mains reset
9	RAM-failure	Mains reset
A	EEPROM-failure	Mains reset
b	Software-failure	Mains reset
H	Power cutoff on the main closing edge	auto Reset **
L	overload of the drive (as well during set-up)	auto Reset **
U	Low voltage on mains	auto Reset **

\*\* No commands are accepted during interference mode. After the malfunction has been corrected, restart the drive again.

### Individual Set-Up

Normal operation

5 sec

#### Force adjustment

display	value
1	10%
2	30%
3	50%
4	80%
5	100%
6	110%
7	120%
8	130%
9	150%

#### Adjustment pre warning time - option red / green light

display	value
1	0s
2	4s
3	6s
4	12s

Only possible when red / green light module is plugged in and b3 not active.

#### Adjustment automatic closing time

display	value
1	10s
2	30s
3	60s
4	120s
5	240s

Adjustment only possible if b3 is set on active

#### Adjustment automatic closing - pre-warning time

display	value
1	1s
2	4s
3	8s
4	12s

#### Adjustment lighting on-time

display	value
1	30s
2	60s
3	120s
4	180s

#### Adjustment additional binary functions

1. reversing	0: entirely 1: 10cm
2. Soft travel short/long	0: 7cm 1: 15cm
3. Automatic closing	0: inactive 1: active
4. Light barrier	0: inactive 1: active
5. Safety edge	0: inactive 1: active
6. Warning light	0: flashing 1: permanent on
7. Load preset values	1: Preset values

Fig. 26



## 4.0 Maintenance

We recommend, that the door system be checked once a year by a professional. The force shutdown, possibly installed safety equipment and the emergency release have to be checked every 4 weeks and have any possible failures repaired immediately by an professional.

The force shut-off can be tested, by putting a 5 cm or higher piece of wood on the floor, in the travel path of the door (Fig. 30). Now close the door. When reaching the obstacle, the door has to stop and reverse (completely or partially, according to the performed setting on the circuit board).

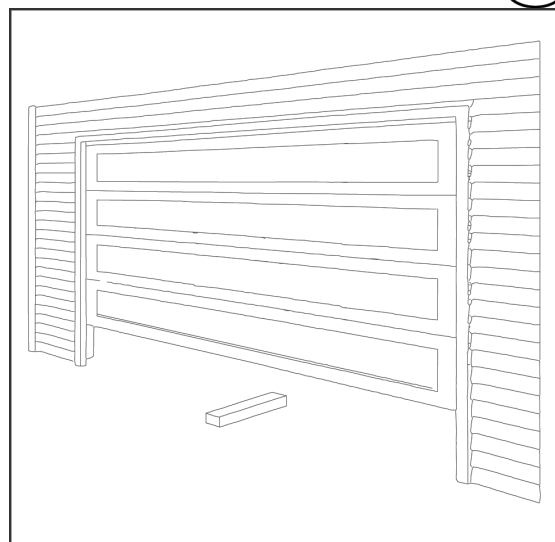
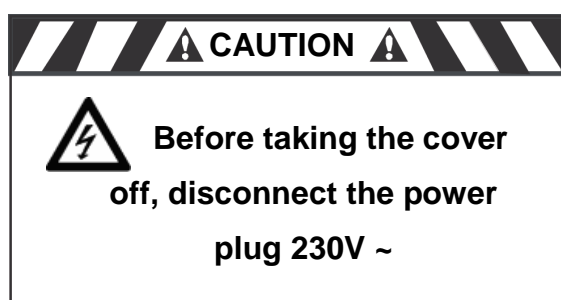

Fig. 30



If an exchange of single components (e.g. circuit board, motor, etc.) of the drive is necessary, first remove the light cover. For that purpose remove both safety screws as shown in Fig. 31.1. After removing the light cover turn out the bulb. Afterwards remove the 4 screws of the cover (Fig. 31.2) and take it off (Fig. 30.3).

**When exchanging the bulb, only a bulb with max. 40 W (E14) may be used.**

Batteries and bulbs are not included in warranty claims.

After finishing the repairs, put back all parts in reverse order.

## 5.0 Demounting and disposal

For demounting and disposal the local safety and disposal regulations have to be followed.

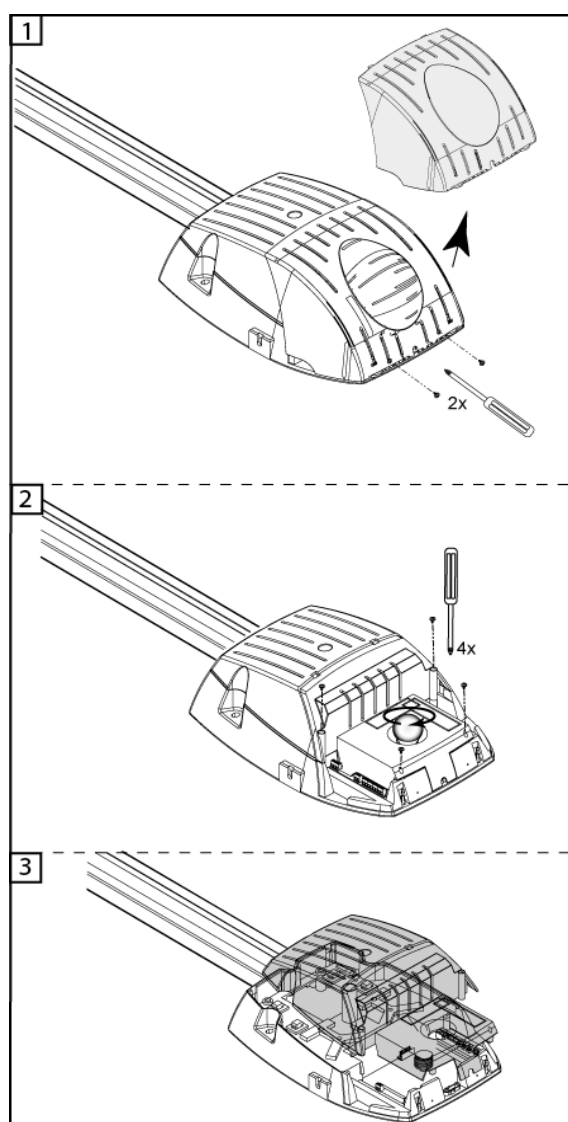

Fig. 31.1-31.3

## 6.0 Failure analysis

### Lighting:

- bulb defective:
  - exchange with 40W/ 230V E14 bulb
- drive is without mains voltage:
  - check power plug and fuses and exchange if necessary

### Radio system:

- door does not run with transmitter
  - check the battery of the transmitter and exchange if necessary.
  - receiver has not learned the code of the transmitter, repeat learning process.
- range is dissatisfying:
  - check the connection and the location of the antenna and correct if necessary.
  - check the output of the battery and exchange if necessary.
  - use a rod aerial.

### circuit board:

- door does not move:
  - check, if the safety inputs are jumpered or safety installations are installed and not connected.
- door only reacts with push button:
  - check the placement of the receiver and exchange if necessary.
- door stops while travelling:
  - door is too tight, check the door mechanic and renew if necessary (only by a professional !!)
- door reverses while moving:
  - check if there is an obstacle in the travel path and remove the obstacle.

### motor:

- motor runs, but the door does not move:
  - check the connection between push rod and door and correct if necessary, check if the trolley is engaged in the chain/belt lock?
- motor jerks:
  - motor gearbox defective, exchange complete motor unit
- motor does not start
  - check, if the hallsensor cable is connected correctly (at the motor and at the circuit board):

## 7.0 Operating Instructions radio system PICO, 868,5 MHz

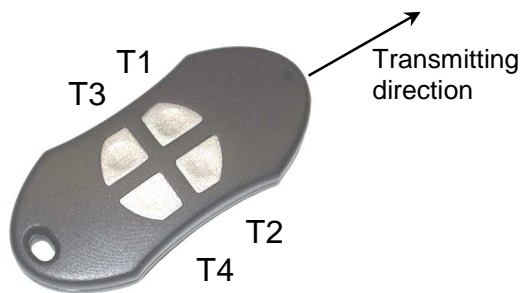

**Application:** remote control for garage door and gate openers

**Technical data:**

- Frequency 868,5 MHz
- Coding: KEELOQ®-Rolling Code System; pre-programmed by the factory
- each receiver has a max. capacity of 28 transmitters, which can be programmed
- Power supply: standard 3 V CR2032 lithium coin cell
- Range approx. 50 m, depending on the surroundings

**Battery replacement:**

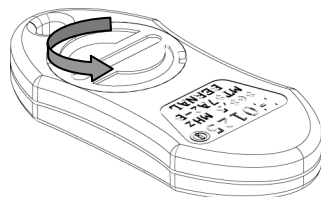

Loosen the battery cap on the rear side of the casing by turning it to the left side (see drawing) with your finger. Insert the new battery with its positive pole forward into the battery cap. Turn the battery cap together with the battery back into the casing.

**IMPORTANT:** Do not throw used batteries into domestic waste; dispose them through battery recycling system!

**Transmitter types:**

2- and 4-channel

**Conformity:**

The radio system conforms to the standards EN300220-3 V1.1.1; EN301489-3 V1.4.1; EN60335-1; EN50371 and may be put in circulation without additional registration in the countries of the EU and in Switzerland.

**HomeLink®-compatible:**

The HomeLink®-System integrated in some car types can also be programmed with this transmitter provided that the software-version of the HomeLink®-System is version 8 or higher.

**Function:**

Hybrid receiver 4-pole (S 401)	pluggable MOLEX-receiver (10-pole)
<p><b>Programming:</b></p> <ol style="list-style-type: none"> <li>1. push the learn button on the PCB until the display shows a „L“ flashing</li> <li>2. push the transmitter button, „L“ lights up short-time and then starts flashing again</li> <li>3. push the transmitter button again, „L“ lights up for about 3 s, then it disappears</li> <li>4. the programming mode is finished automatically, the radio system is ready for use</li> </ol>	<p><b>Programming:</b></p> <ol style="list-style-type: none"> <li>1. push the learn button on the receiver short-time, the red LED lights up</li> <li>2. push the transmitter button, the red LED extinguishes</li> <li>3. push the transmitter button again, the red LED flashes for about 5 s and then extinguishes</li> <li>4. the radio system is ready for use</li> </ol>
<p><b>Erasure:</b></p> <p>Keep the learn button pushed down for about 5 s, „L“ lights up and then extinguishes, all transmitters are erased</p>	<p><b>Erasure:</b></p> <p>Keep the learn button on the receiver pushed down for about 10 s, until the red LED extinguishes, all transmitters are erased</p>



## 8.0 TÜV-Certificate

**ZERTIFIKAT**  
Nr. Z1A 05 10 29090 011

**Zertifikatsinhaber:**  
Bernal Torantriebe GmbH  
Industriepark Sandwiesen  
72793 Pfullingen  
DEUTSCHLAND

29090

**Produktionsstätte(n):**  
29090

**Prüfzeichen:**

**Produkt:**  
Garagentorantriebe

**Modell(e):**  
Sensor-Line S401-60, Sensor-Line S401-80  
Sensor-Line S401-100, Sensor-Line S401-120

**Kenndaten:**  
Nennspannung: 230V AC 50Hz  
Nennaufnahme: 110W-120W-150W-180W  
Schutzklasse: I  
Schutzgrad: IP20  
Beleuchtung: max. 40W  
Betriebsart: ED 30%  
Anmerkung: Mit integriertem Einklemmschutzsystem

**Geprüft nach:**  
EN 60335-2-95:2001  
EN 12453 Abs. 5.1.1.5:2000  
EN 12445 Abs. 5:2000

**ZERTIFIKAT**  
Nr. Z1A 05 10 29090 011

**Zertifikatsinhaber:**  
Bernal Torantriebe GmbH  
Industriepark Sandwiesen  
72793 Pfullingen  
DEUTSCHLAND

29090

**Produktionsstätte(n):**  
29090

**Prüfzeichen:**

**Produkt:**  
Garagentorantriebe

**Modell(e):**  
Sensor-Line S401-60, Sensor-Line S401-80  
Sensor-Line S401-100, Sensor-Line S401-120

**Kenndaten:**  
Nennspannung: 230V AC 50Hz  
Nennaufnahme: 110W-120W-150W-180W  
Schutzklasse: I  
Schutzgrad: IP20  
Beleuchtung: max. 40W  
Betriebsart: ED 30%  
Anmerkung: Mit integriertem Einklemmschutzsystem

**Geprüft nach:**  
EN 60335-2-95:2001  
EN 12453 Abs. 5.1.1.5:2000  
EN 12445 Abs. 5:2000

Das Produkt entspricht den Anforderungen des deutschen Geräte- und Produktsicherheitsgesetzes. Es kann mit den oben abgebildeten Prüfzeichen gekennzeichnet werden. Die Verwendung des GS-Zeichens ist erlaubt bis zum angegebenen Zeitpunkt, die Verwendung des TÜV-Marks ist unbefristet, sofern das Zertifikat nicht gekündigt wird. Umseitige Hinweise sind zu beachten.

**Prüfbericht Nr.:** 70107387

**GS-Zeichen gültig bis:** 2010-10-14

**Datum:** 2005-10-14

Seite 1 von 2

TÜV Product Service GmbH · Zertifikatsstelle · Ridlerstrasse 65 · 80339 München · Germany

## 9.0 TÜV-Doors

**Zertifikat**  
Nr. Z1A 05 10 29090 011

Die folgenden Tore erfüllen in Verbindung mit den auf Seite 1 genannten Antrieben die Anforderungen der Prüfspezifikation.

Somit entsprechen die Kombinationen dem Abschnitt 4.3.2 und 4.3.3 der EN 13241: 2003

Bezeichnung	Hersteller	Abmessungen	Torblattgewicht
Deckensektionaltor ISO 45	Novoferm GmbH	5250 mm x 2200 mm Stärke Torabschlussprofil: ca. 25 mm	143 kg
Deckensektionaltor GSW 20	Teckentrup GmbH	5.000 mm x 2.250 mm Stärke Torabschlussprofil: ca. 25 mm	130 kg
Deckensektionaltor LPU 40	Hörmann	5.000 mm x 2.250 mm Stärke Torabschlussprofil: ca. 50 mm	104 kg
Deckensektionaltor ISO 45	Novoferm Siebau GmbH	5000 mm x 2250 mm Stärke Torabschlussprofil: ca. 50 mm	142 kg
Schwingtor	Novoferm Siebau GmbH	2750 mm x 2125 mm	44,3 kg
SLG-K100	Guttomat Sektionaltore GmbH	4970 mm x 2460 mm Stärke Torabschlussprofil: ca. 45 mm	152 kg
Deckensektionaltor Eurotrend ISO	Normstahl GmbH	5000 mm x 2200 mm, Stärke Torabschlussprofil: ca. 50 mm	146 kg

**Bemerkung**

Die ausgewählten Tor-Typen stehen stellvertretend für weitere Abmessungen des gleichen Typs wenn deren Geometrie und Ausführung günstigere Bedingungen sicherstellen.

Seite 2 von 2

TÜV Product Service GmbH · TÜV SÜD Gruppe · Zertifikatsstelle · Ridlerstrasse 65 · 80339 München · Germany

Further certified combinations of doors and the S 401 on request.

10.0 EC-Manufacturer's Declaration

**EG- Herstellererklärung**

EC- Manufacturer's Declaration  
Déclaration du fabricant UE

im Sinne der EG- Maschinenrichtlinie 98/37/EG Anhang II B  
in accordance with EC Machine Directive 98/37/EC Appendix II B  
dans l' esprit de la directive machines UE 98/37/UE Annexe II B

Der Hersteller/ The manufacturer/Par la présente, le fabricant

**BERNAL Torantriebe GmbH**  
**Industriepark Sandwiesen**  
**D-72793 Pfullingen**

erklärt hiermit/ declares hereby that/ déclare:

**Der Torantrieb; Typ: S401- 60/80/100/120 mit der Steuerung Nr.: B 300.01**  
The door drive, type with the control no.:  
La motorisation de portail, type avec la commande n° :

**entspricht den folgenden EG-Richtlinien:**  
conforms to the following EC directives:/ satisfait aux directives UE suivantes:

- |   |  |
|---|--|
| <b>98/37/EG</b><br>98/37/EC<br>98/37/UE       | <b>Maschinenrichtlinie ( ehemals 89/392/EWG )</b><br>Machine directive ( formerly 89/392/EEC )<br>Directive machines (auparavant 89/392/ CEE )   |
| <b>89/336/EWG</b><br>89/336/EEC<br>89/336/CEE | <b>EMV- Richtlinie (mit Änderungen 91/263/EWG,92/31/EWG,93/68 EWG )</b><br>EMI directives (with 91/ 263EEC, 92/31/EEC, 93/68 EEC amendments)<br>Directive CEM ( avec modifications 91/263/CEE, 92/31/CEE, 93/68 CEE) |
| <b>73/23/EWG</b><br>73/23/EEC<br>73/23/CEE    | <b>Niederspannungsrichtlinie ( mit Änderung 93/68/EWG )</b><br>Low voltage directive ( with 93/68/EEC amendment )<br>Directive basse tension ( avec modification 93/68/EEC )   |

**Inbesondere wurden die folgenden nationalen technischen Normen angewandt:**  
The following national, technical standards were applied./ En particulier, les normes techniques nationales  
suivantes ont été appliquées:

**DIN V VDE 0801; EN 60335-1; EN 12445; EN 12453; EN 954-1 ; EN 60204-1**

**Hinweis: Die Inbetriebnahme der Toranlage, in der dieser Torantrieb eingebaut werden soll, ist so lange untersagt, bis festgestellt wurde, dass die Toranlage den Bestimmungen der Richtlinie 98/37/EG entspricht.**

Note: Putting the door installation, in which this door drive is to be incorporated, is forbidden until it has been established that the door installation conforms to the regulations of directive 98/37/EC.  
Remarque: La mise en service du système de portail dans lequel cette motorisation doit être intégrée est déconseillée jusqu'à ce qu'il soit constaté que ce système de portail satisfait aux prescriptions de la directive 98/37/UE.

12.07.04

  
\_\_\_\_\_  
- Geschäftsführer -  
- Managing Director / Gérant -

  
\_\_\_\_\_  
- Technischer Leiter -  
- Technical Director / Directeur technique-

**11.0 EC- Manufacturer's Declaration according to EC Directive**

**We, the company**.....

.....

declare that the garage door installation conforms to the following  
**EC directives: 98/37/EC Machine directive appendix II**

The component doors drive S 401 .....

is in the garage door installation, supplied by: .....

Type: .....

Height: .....cm

Width: .....cm

integrated.

**Date:** .....

**Signature:** .....



**12.0 Handing over**

of the garage door drive

**Type:** .....

**and the corresponding Instruction manual**

.....  
.....

**Customer's address**

**Handing over date**

**Signature of customer**